

Ergonomic

- / State-of-the-art design makes a clear footwell with wellplaced pedals which give plenty of room for large feet space and help the driver's comfort working.
- / The simple, concise instrument panel minimizes confusion but gives the key warnings to operator.
- / Hydraulic levers can be mounted beside the battery or on the scuttle, giving easy access from either side. The conventional cabin layout makes the inexperienced operator work easily without time-consuming training.
- / Adjustable steering wheel and seat make the operator in comfortable working position.



Maneuverability

- / Drive to the rear steering wheel gives safe truck operation in confined spaces. The turning angle of rear wheel is upto 90 degree, compared with the same load capacity 4 pivot trucks, the turning radius is smaller about 400 to 450mm.
- / Driving speed is automatically reduction during cornering.



Reliability

- / AC motor is the simple brushless motor, less maintenance and better suitability for wet & explosive conditions.
- / Maintenance is easy and low-cost.

Side battery change

- / 24V battery is ideal for two or three shifts requirements, and side battery change is a perfect option to change the batteries quickly.



ZHEJIANG HANGCHA IMP. & EXP. CO., LTD.

Factory site: 666 Xiangfu Road,
Hangzhou, Zhejiang, China (311305)

Tel: +86-571-88926735 88926755
Fax: +86-571-88926789 88132890

sales@hcforklift.com
www.hcforklift.com



Follow us on
Facebook



Follow us on
YouTube



Follow us on
WeChat



ISO14001
ISO14001:2015



ISO9001
ISO9001:2015



HANGCHA trucks conform
to the European Safety
Requirements.

HANGCHA GROUP CO., LTD. reserves the right to make any changes without notice concerning colors, equipment, or specifications detailed in this brochure, or to discontinue individual models. The colors of trucks, delivered may differ slightly from those in brochures.

2018 VERSION 1 COPYRIGHT 2018/07



A series 3-pivot Rear Drive Electric Forklift

with capacities of 1,500kg

The World of Hangcha



A series 3-pivot Rear Drive Electric Forklift

A series 1.5t rear-wheel driving three pivot electric forklift truck is very suitable for operating in limited space, with small turning radius, which is the ideal forklift truck in store, supermarket and warehouse, etc.

Standard specification

- / Solid tyre
- / Emergency disconnect switch
- / Full suspension seat
- / Drive, lift, steering controlled
- / Self-diagnose system
- / 2 spools valves
- / 3m wide view mast
- / Adjustable steering wheel
- / Multi-function LCD display and trucklighting system
- / Rear view mirror
- / Tool box
- / Side battery change

Options

- / Drive wheel with Pneu tyres
- / 3 or 4 spools control valves
- / 4.3-6m full free triplex mast
- / 2.5-4.5m full free duplex mast
- / Different length forks
- / Attachments
- / Different load backrest



1.5t Three-wheel Forklift Specification

		HANGCHA GROUP CO.,LTD.		
Distinguishing mark	1.1	Manufacturer	HANGCHA GROUP CO.,LTD.	
	1.2	Manufacturer's model designation	CPDS15-AHC2	CPDS15-AHD2
	1.3	Drive: electric (battery or mains), diesel, petrol, fuel gas	Electric	Electric
	1.4	Operator type: hand, pedestrian, standing, seated, order-picker	Seated	Seated
	1.5	Load capacity	Q /kg	1500
	1.6	Load centre distance	c /mm	500
	1.8	Load distance, center of drive axle to fork	x /mm	365
	1.9	Wheelbase	y /mm	1220
	Weight	2.1	Service weight with battery	kg
2.2		Axle loading with load, front/rear	kg	3930/570
2.3		Axle loading, unladen front/rear	kg	1370/1630
Wheel & Tyres	3.1	Tyres: solid rubber, superelastic, pneumatic, polyurethane	solid rubber	solid rubber
	3.2	Tyre size - front	18x7-8	18x7-8
	3.3	Tyre size - rear	200/50-10	200/50-10
	3.5	Wheel, number operator/load side (x=drive)	2/1x	2/1x
	3.6	Tread, front	b10/mm	835
	3.7	Tread, rear	b11/mm	/
Dimensions	4.1	Tilt of mast/fork carriage forward/backward	α/β(°)	5/6
	4.2	Height, mast lowered	h1/mm	1980
	4.3	Free lift	h2/mm	155
	4.4	Lift	h3/mm	3000
	4.5	Height, mast extended	h4/mm	3955
	4.7	Height of overhead guard (cabin)	h6/mm	2105
	4.8	Seat height/stand height	h7/mm	940
	4.12	Coupling height	h10/mm	500
	4.19	Overall length	l1/mm	2785
	4.20	Length to face of forks	l2/mm	1865
	4.21	Overall width	b1/mm	990
	4.22	Fork thickness	s/e/ l mm	35/100/920
	4.23	Fork carriage to DIN 15173 - class/form A or B		ISO II A
	4.24	Fork carriage width	b3/mm	1000
	4.31	Ground clearance, with load, below mast	m1/mm	100
4.32	Ground clearance, centre of wheelbase	m2/mm	100	
4.33	Aisle width for pallets 1000 x 1200 crossways	Ast/mm	3160	
4.34	Aisle width for pallets 800 x 1200 lengthways	Ast/mm	3285	
4.35	Turning radius	wa/mm	1510	
Performance	5.1	Travel speed, laden/unladen	km/h	9/9.5
	5.2	Lift speed laden	m/s	0.220/0.330
	5.3	Lowering speed laden	m/s	0.580/0.480
	5.6	Max. Drawbar pull, laden/unladen	N	6400/6300
	5.7	Gradeability, laden/unladen	%	7/9
	5.9	Acceleration time, laden/unladen (0-10m)	s	6.0/5.8
Motors	6.1	Drive motor rating S2 60min.	kw	AC 4
	6.2	Lift motor rating S3 15%	kw	AC 8.6
	6.3	Battery equipment to DIN 43531/35/36 A, B, C, no		DIN 43535 A
	6.4	Battery voltage, nominal capacity(5h)	V/Ah	24/920
	6.5	Battery weight	kg	675
	6.6	Energy consumption acc. to VDI cycle	kWh/h	3.5
Other	9.1	Drive control		CURTIS AC
	10.1	Operating pressure for attachments	bar	145
	10.2	Oil volume for attachments	l/min	16
	10.7	Sound pressure level at the driver's seat	dB(A)	< 70

1.5t Three-wheel Forklift Mast Specification

Type	Mast fork height	Overall height				Free lift		Tilting range		Load capacity at 500mm
		Lowered		Extended		With backrest	Without backrest	Forward	Backward	
		mm	mm	mm	mm					
Duplex mast	2700	1830	3655	3233	155	155	6	5	1500	
	3000	1980	3955	3533	155	155	6	5	1500	
	3300	2130	4255	3833	155	155	6	5	1500	
	3500	2230	4455	4033	155	155	6	5	1500	
	3600	2330	4555	4133	155	155	6	5	1500	
	4000	2580	4955	4533	155	155	3.5	5	1500	
	4300	2730	5255	4833	155	155	3.5	5	1400	
	4500	2830	5455	5033	155	155	3.5	5	1300	
	2500	1745	3445	3059	800	1186	6	5	1500	
	2700	1845	3645	3259	900	1286	6	5	1500	
Full free duplex mast	3000	1995	3945	3559	1050	1436	6	5	1500	
	3300	2145	4245	3859	1200	1586	6	5	1500	
	3500	2245	4445	4059	1300	1686	6	5	1500	
	3600	2295	4545	4159	1350	1736	6	5	1500	
	4000	2545	4945	4559	1600	1986	3.5	5	1500	
	4000	1945	4955	4584	1000	1371	3.5	5	1500	
	4300	2045	5255	4884	1100	1471	3.5	5	1400	
	4500	2095	5455	5084	1150	1521	3.5	5	1300	
	4800	2245	5755	5384	1300	1671	3.5	5	1200	
	5000	2345	5955	5584	1400	1771	3.5	5	1150	
Triplex full free mast	5500	2545	6455	6084	1600	1971	3.5	5	1050	
	6000	2795	6955	6605	1850	2200	3.5	5	950	
	6500	2995	7455	7105	2050	2400	3.5	5	750	

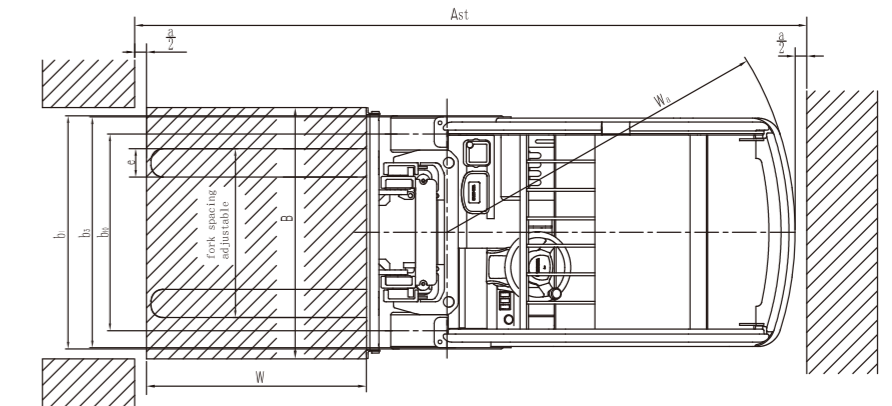
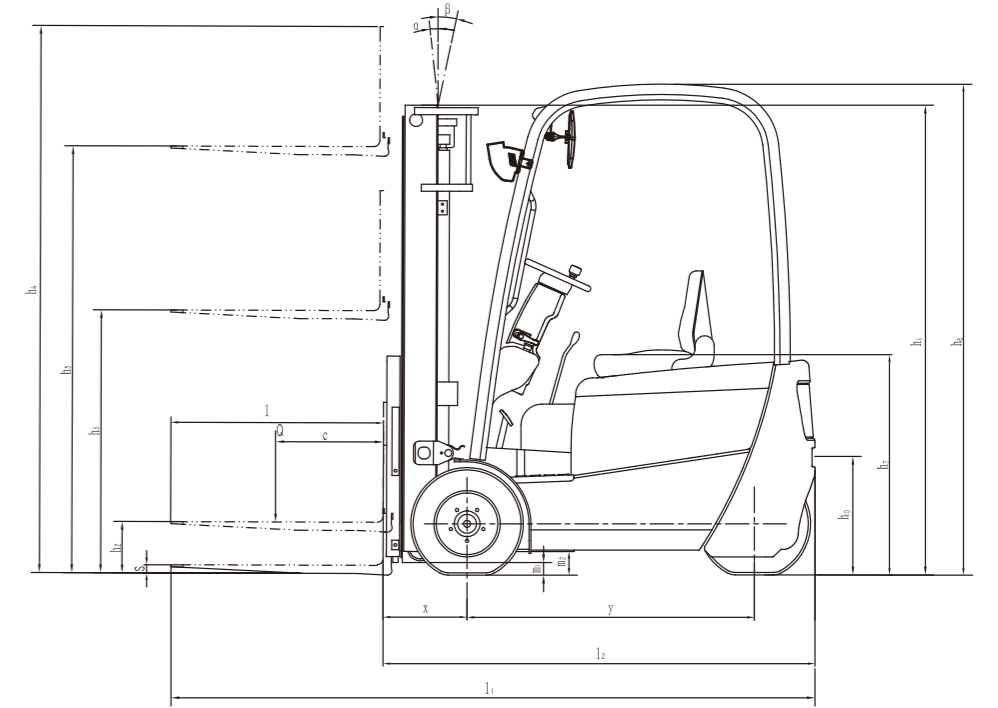

a=200 mm safety clearance
 $AST = a + Wa + \sqrt{(W + x)^2 + (B/2)^2}$

